

## INSTALLING NEW TERMINALS

Two plug wire terminals are supplied with this kit. To install the terminals it is recommended to use a Plug Wire Tool, such as the MSD Pro-Crimp Tool, PN 3505, however you can produce a solid crimp with a pair of pliers when used with care. The 90° terminal features two sets of crimp tabs; one for the wire sleeve and the other for the conductor of the wire. The following procedure outlines the installation of the Dual Crimp Terminal:

1. Strip approximately 1/4" of sleeving from the wire. Use extreme care not to damage the conductor.
2. Position the conductor between the conductor crimp tabs. Using the needle nose pliers carefully crimp the tabs towards each other until the conductor is held secure.
3. Carefully fold the crimp tabs over the sleeve of the wire until a firm grip is held. Use caution not to tear into the sleeve.

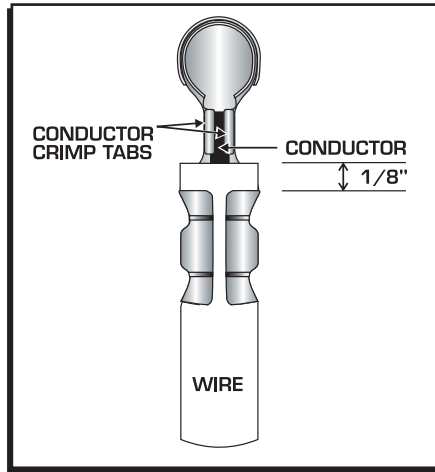

Figure 7 Dual Crimp Tab.

### Service

In case of malfunction, this MSD component will be repaired free of charge according to the terms of the warranty. When returning MSD components for warranty service, **Proof of Purchase** must be supplied for verification. After the warranty period has expired, repair service is based on a minimum and maximum fee.

**All returns must have a Return Material Authorization (RMA) number** issued to them before being returned. To obtain an RMA number please contact MSD Customer Service at 1 (888) MSD-7859 or visit our website at [www.msdisignition.com/rma](http://www.msdisignition.com/rma) to automatically obtain a number and shipping information.

When returning the unit for repair, leave all wires at the length in which you have them installed. Be sure to include a detailed account of any problems experienced, and what components and accessories are installed on the vehicle. The repaired unit will be returned as soon as possible using Ground shipping methods (ground shipping is covered by warranty). For more information, call MSD Ignition at (915) 855-7123. MSD technicians are available from 7:00 a.m. to 6:00 p.m. Monday - Friday (mountain time).

### Limited Warranty

MSD IGNITION warrants this product to be free from defects in material and workmanship under its intended normal use\*, when properly installed and purchased from an authorized MSD dealer, for a period of one year from the date of the original purchase. This warranty is void for any products purchased through auction websites. If found to be defective as mentioned above, it will be repaired or replaced at the option of MSD Ignition. Any item that is covered under this warranty will be returned free of charge using Ground shipping methods.

This shall constitute the sole remedy of the purchaser and the sole liability of MSD Ignition. To the extent permitted by law, the foregoing is exclusive and in lieu of all other warranties or representation whether expressed or implied, including any implied warranty of merchantability or fitness. In no event shall MSD Ignition or its suppliers be liable for special or consequential damages.

\*Intended normal use means that this item is being used as was originally intended and for the original application as sold by MSD Ignition. Any modifications to this item or if it is used on an application other than what MSD Ignition markets the product, the warranty will be void. It is the sole responsibility of the customer to determine that this item will work for the application they are intending. MSD Ignition will accept no liability for custom applications.

## MSD Blaster Coil PN 8200 and PN 8203

### Parts Included:

1 - Blaster Coil	2 - 45° Faston Tabs	1 - 0.8 Ohm Resistor
1 - Power Tower	2 - Female Fastons	1 - 18" Gray Wire
1 - 90° Coil Boot/Terminal	1 - Blaster Boot/Terminal	

**WARNING:** During installation, disconnect the battery cables. When disconnecting the battery, always remove the Negative cable first and install it last.

**Note:** This Blaster Coil is supplied with a ballast resistor. If your application uses a points distributor, the ballast must be used. Late model electronic ignitions or an MSD Ignition do not require the ballast.

## REMOVAL

1. Label the location of the coil wires (+ and -) and remove the wires from the coil.
2. Remove the high voltage wire from the coil and remove the coil from its mount.
3. Position the Blaster Coil in the mount and tighten.

## INSTALLATION

**Note:** The Blaster Coil will mount in most factory canister coil mounts. MSD also offers a Chrome Bracket, PN 8213. It is recommended to mount the coil in an upright position.

### STOCK POINTS IGNITION

If you are installing the Blaster Coil with the stock points ignition (Figure 1), MSD Blaster Ignition or an MSD 5 Ignition Control (Figure 2), the supplied 0.8 ohm ballast resistor must be installed on the coil positive (+) wire.

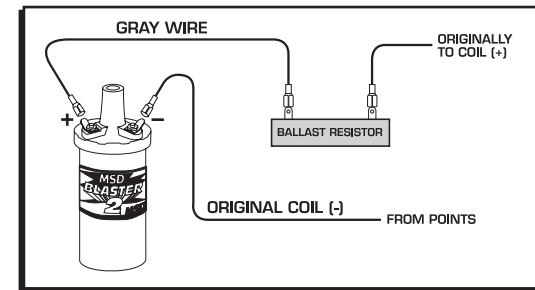

Figure 1 Wiring to the Stock Ignition.

1. Install the original negative (-) coil wire (Figure 1).
2. Install the supplied connector on the coil positive (+) wire and install it to ballast resistor. The Ballast Resistor should be mounted to a solid mount such as the firewall.
3. Connect the supplied Gray wire from the Ballast to the Coil positive (+) terminal.
4. Install the high voltage wire. If necessary, use the supplied Power Tower (Figure 4).

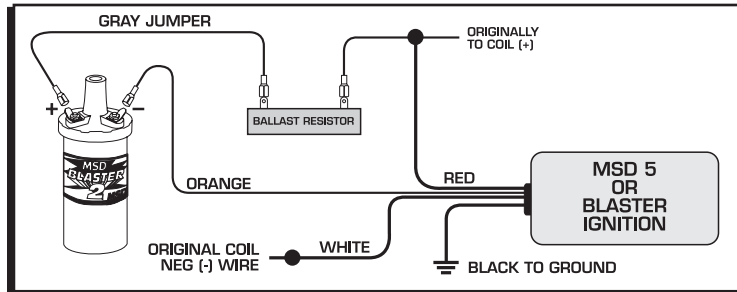

Figure 2 Wiring to an MSD Blaster Ignition or MSD 5.

### MSD 6 OR 7 SERIES IGNITION CONTROL

The MSD 6 or 7 Series Ignitions receive 12 volts directly from the battery and are responsible for delivering the positive voltage to the coil. Therefore, a 12 volt source wire is not required at the coil. When the installation is complete, there will only be two wires making direct contact to the coil terminals: the Orange wire from the MSD connects to the coil positive (+) terminal. The Black wire from the MSD connects to the coil negative (-) terminal (Figure 3).

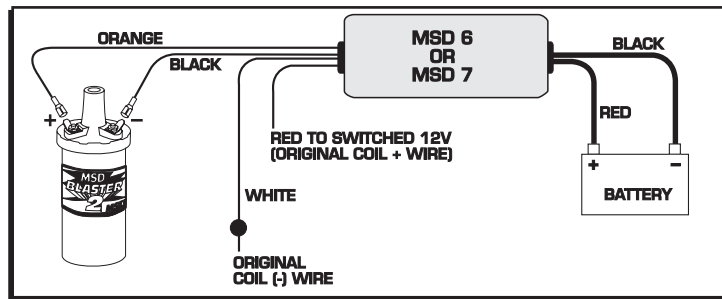

Figure 3 Wiring to an MSD 6 or 7 Series Ignition.

### INSTALLING THE POWER TOWER

In some applications the factory coil terminal/boot may not match the Blaster 2. In this case, use the supplied Power Tower to adapt the wire.

1. Loosen the tip of the Tower.
2. Push the screw head-end of the Power Tower into the coil (Figure 4).
3. Hold the housing of the Tower and tighten the tip until the Tower is secure.

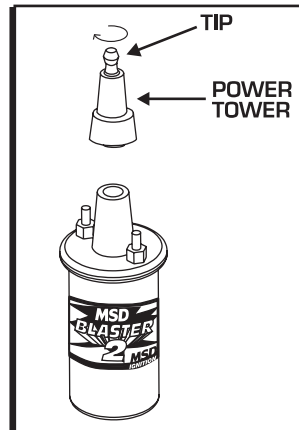

Figure 4 Installing the Power Tower.

### REPLACING AN E-CORE STYLE COIL (FORD TFI OR GM DUAL COIL CONNECTOR)

The MSD Blaster Coils can be used in place of your late model e-core style coil. The Ballast Resistor does not need to be installed in either of these installations.

**Ford TFI:** Look on the original coil to determine the coil negative and coil positive wires. Coil positive is usually Red/Lt. Green and negative is generally Dark Green/Yellow. Cut the wires and install the two female Faston terminals to the wires.

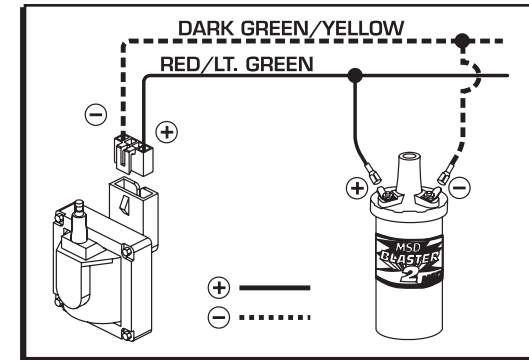

Figure 5 Wiring to a Ford TFI Coil.

**GM Dual Connector Coil:** There are four (sometimes three) wires going into the GM Coil. Two wires are positive and two (sometimes one) are negative. It is important to install each wire to the MSD Coil. Cut the wires and splice the corresponding polarity wires together and install the supplied female faston connectors.

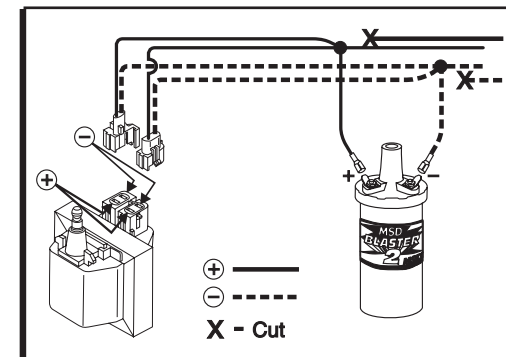

Figure 6 Wiring to a GM Dual Connector Coil.