

Cyclone™ Headers

Custom Tail Pipe Dimensions

Use the following procedures to determine the dimensions required to manufacture your new Hardin Marine Custom Tailpipes.

1. Install your new Hardin Marine Cyclone Headers following the instructions provided.
2. This measurement determines the maximum allowable height of the tailpipes. Measure the vertical distance from each header flange to the engine hatch (in the closed position) or to the nearest obstruction. This is measurement "A", see Figure 1.

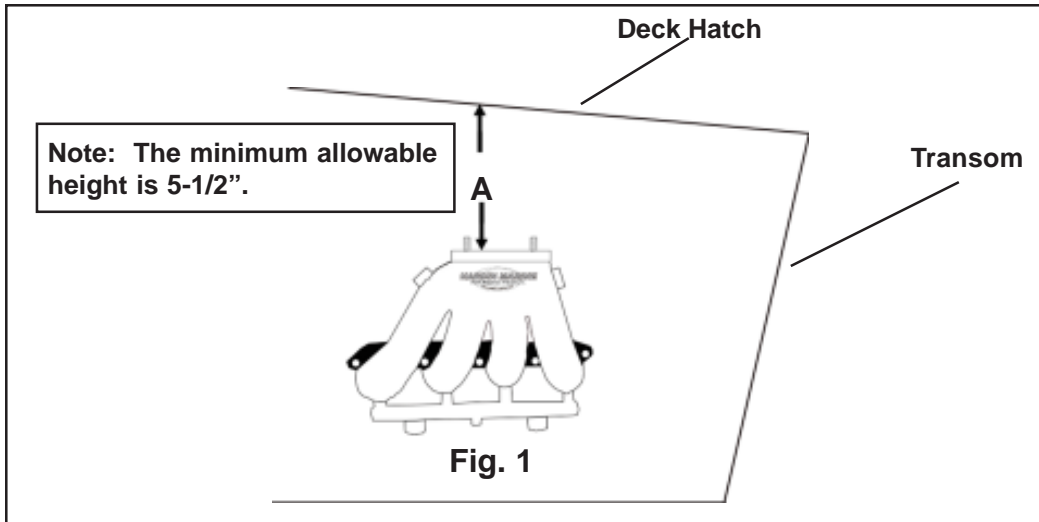

3. See Figure 2. Measurement "B" is used to determine the distance from the header to your transom. Lay a straight edge over the top flange of the header, and against the inboard studs (toward the center of the engine). Holding the straight edge flat on the header flange and against the two inboard studs, slide it back until it touches the inside of the transom. Mark the spot where the lower inboard edge touches the transom. We will refer to this reference point as mark "Y". It is imperative that this mark is straight back from the manifold studs.

Next, measure the distance from the back of the rear flange stud to mark "Y" on the transom in a straight line. This is measurement "B". Take this same measurement for each manifold.

Note: Header stagger will cause the "B" dimension for the starboard pipe to be longer than the port pipe. This dimension may also vary due to irregularities in the transom thickness.

Important - For a wet style pipe configuration, the factory will subtract 6" from the "B" dimension to allow for a rubber hose and transom exhaust tip connection. If you require pipes that are either longer or shorter, please specify and explain.

4. Again using figure 2, Measurement "C" is the vertical distance from mark "Y" to the center of the exhaust hole in the transom. Indicate whether the exhaust hole is above or below mark "Y".

5. Again using Figure 2, measurement "G" is the horizontal distance from the transom mark "Y" to the center of each exhaust hole for each tailpipe. Indicate whether each hole is inboard (towards the center of the engine), or outboard (towards the boats gunwale) of mark "Y".

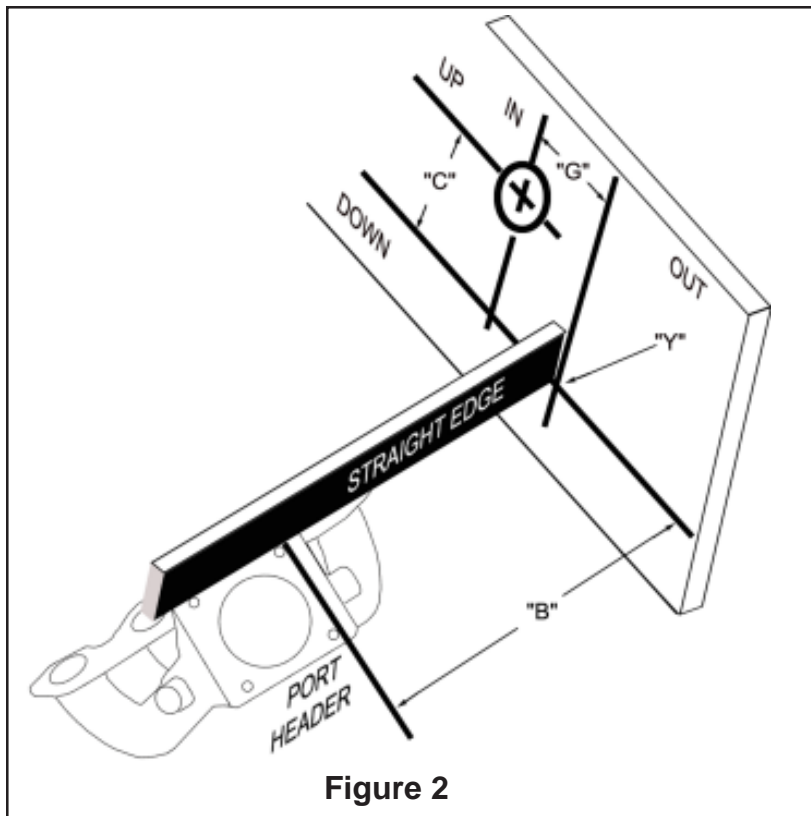

6. Measurement "D" (see Figure3) is only used for pipes that pass through the transom, (not with pipes that couple to exhaust tips with hose). Measurement "D" is the distance from the inside of the transom to the end of the tailpipe. Most transoms are from 2" to 3" thick and the pipes should extend at 4" to 5" beyond the outside of the transom to allow for the installation of silencers should they be needed.

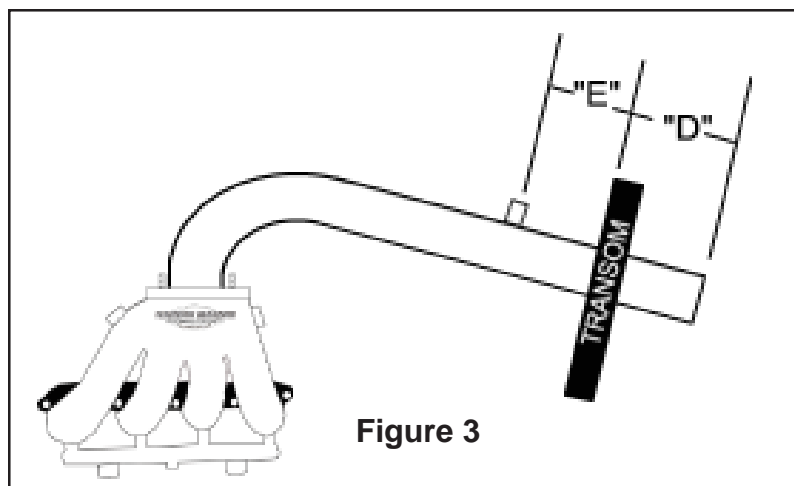

7. Measurement "E" is only used on "dry style" tailpipes that pass through the transom (see Figure 3). This measurement determines the location of the water discharge fitting on dry style tailpipes. Measurement "E" is the distance from the inside of the transom to the center of the discharge fitting (recommended to be 4"). The fitting will be a 3/4" female NPT pipe bung.

8. Measurement "F" is the distance between the centers of the thru-transom exhaust ports (see Figure 4). For single engines use the starboard side only on the measurement sheet. For tailpipes intended to run straight back from the headers, this measurement should be 28" Check for obstacles along the straight line from the header to the transom holes.

9. Measurement "H" is for twin engine applications only (See Figure 4). Measure the distance between the centers of the two inboard exhaust holes. A minimum of 6-1/4" is recommended for installation of silencers.

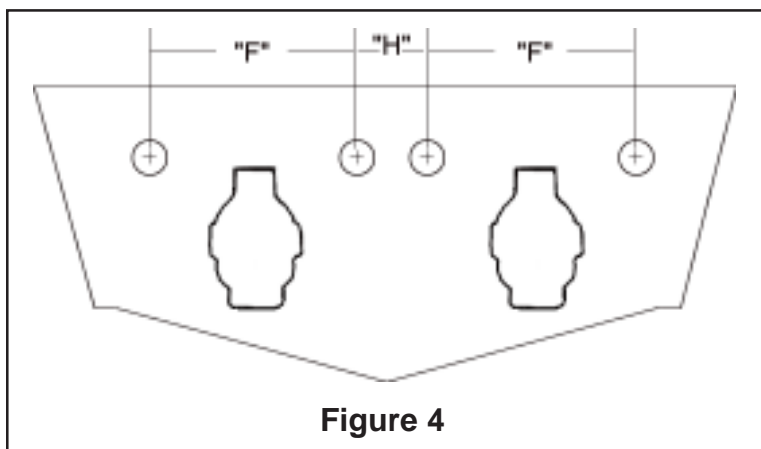

Figure 4

Please sign and date the Cyclone Header custom tailpipe measurement sheet and return it to Hardin Marine. Please be sure to include your name, address, phone, and fax number so that we may contact you. Please double check all your measurements. It is imperative that they are precise and correct.

Advance payment is required for custom tailpipes. The tailpipes are built to your specifications, additional charges may be incurred to correct or replace tailpipes due to incorrect measurements.

HARDIN MARINE CUSTOM TAILPIPE MEASUREMENTS

Name _____ Date _____

Address _____

City _____ State _____ Zip Code _____

Phone _____ Fax _____

CAUTION - Please Triple Check your measurements. Your tailpipes will be built to your specifications below. Hardin Marine is not responsible for tailpipes that do not fit due to incorrect measurements. Additional charges may be incurred should alteration or replacement be necessary.

Single or Port Engine	
Port Pipe	Stbd. Pipe
A. _____	_____
B. _____	_____
C. _____ Up or Down?	_____
D. _____	_____
E. _____	_____
F. _____	_____
G. _____ In or Out?	_____
H. _____	_____

Stbd Engine	
Port Pipe	Stbd. Pipe
A. _____	_____
B. _____	_____
C. _____ Up or Down?	_____
D. _____	_____
E. _____	_____
F. _____	_____
G. _____ In or Out?	_____
H. _____	_____

Pipe O.D. Size (4" / 4.5" / 5" / 6")	PLEASE CIRCLE ANSWER	(WET / DRY) Pipes
Extra Rise (NONE / 3" / 6")		Silent Choice? (Yes / No)

Additional Comments: _____

Please Fax to Hardin Marine
(386) 445-1122

Customer Signature

