

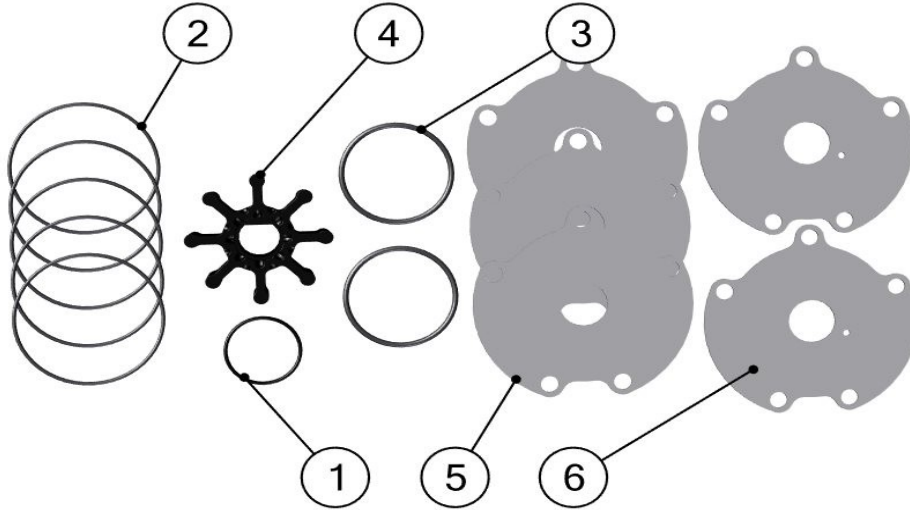

SINGLE STAGE STD REBUILD KIT

625-4180



ID	Part #	Qty
1	625-1026	1
2	625-1037	5
3	625-1134	2
4	625-4011	1
5	625-4018	3
6	625-4019	2

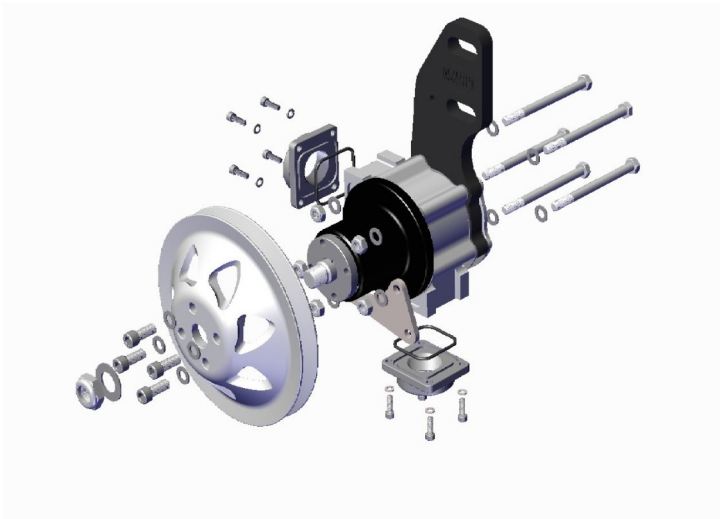

- **Step 1:**

- 1) Remove sea pump pulley using 15/16 socket and 1/4 hex socket.
- 2) Remove inlet and outlet adapters using 5/32 allen key.
- 3) Using 1/2 socket or wrench remove nuts and bolts holding sea pump together.

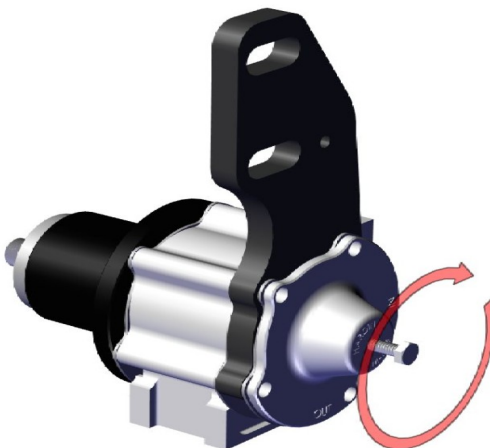

- **Step 2:**

- 1) This is for generation 2 sea pumps only.
- 2) Using 5/32 allen key remove the bolt that is installed into the rear cover.
- 3) Screw a 1/4 fine bolt into the rear cover. Tighten bolt clockwise to remove rear cover and bearing.



SINGLE STAGE STD REBUILD KIT

625-4180

- **Step 3:**

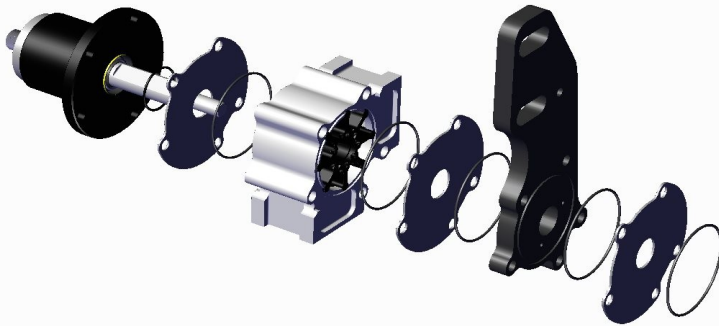

1) Remove the sea pump bracket, body, wear plates and impeller.

2) Discard the impeller, o-rings and wear plates.

3) Inspect and clean body, bracket, rear cover and front snout with shaft.

- **Step 4:**

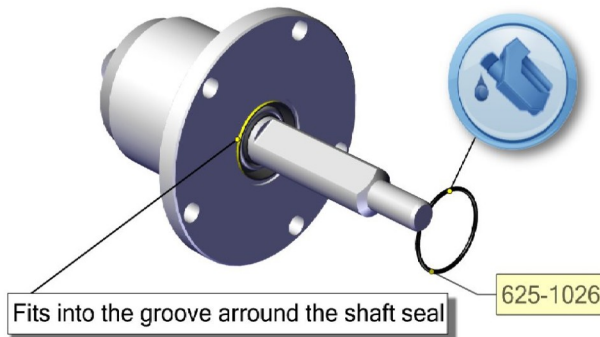

1) Apply petroleum jelly to the small 625-1026 o-ring.

2) Install into the groove around the the shaft seal.

- **Step 5:**

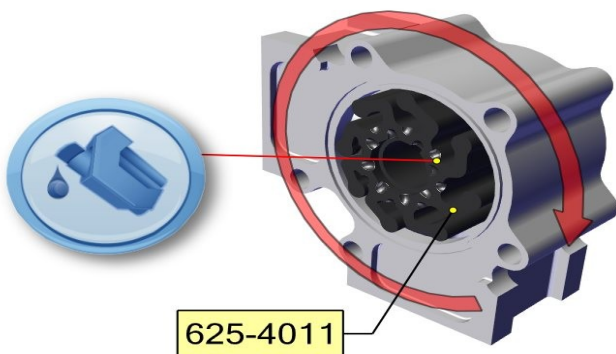

1) Apply petroleum jelly to the inside of the sea pump body and to both ends of the impeller.

2) Notice the rotation shown. This is for typical port side mounted sea pump standard rotation engine. When installing on to the shaft keep track of which side is front.



SINGLE STAGE STD REBUILD KIT

625-4180

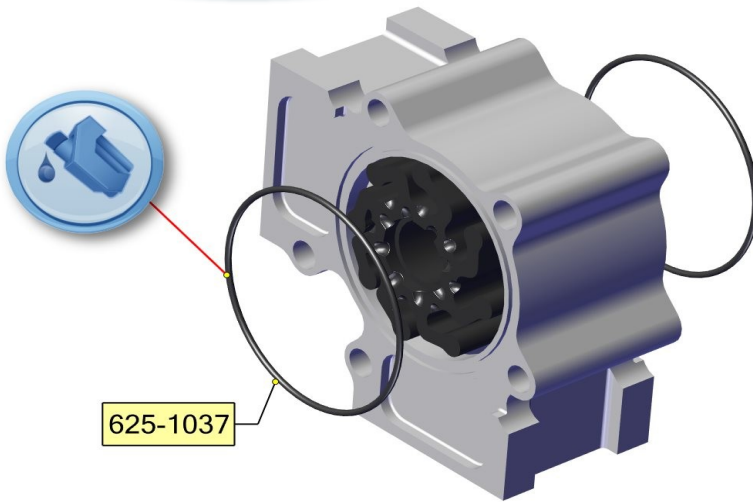

- **Step 6:**

1) Apply petroleum jelly to both 625-1037 o-rings and install in the sea pump body on both sides of the body.



- **Step 7:**

1) Apply petroleum jelly to both 625-1037 o-rings and install into the grooves into the bracket on both sides.

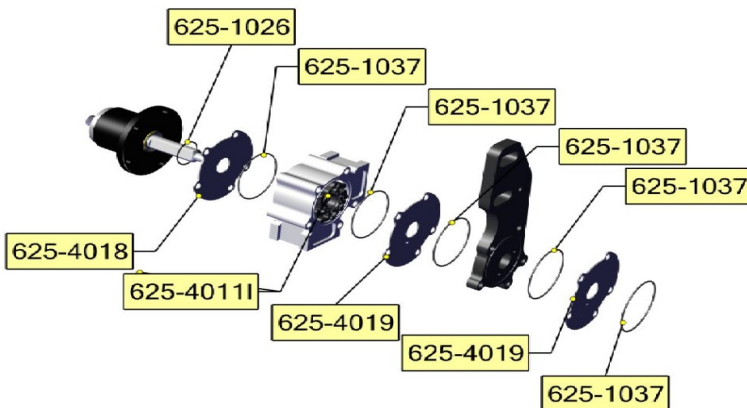

- **Step 8 Gen 1:**

1) Slide the components onto the shaft as shown.
2) Notice 625-4019 wear plate hole position. This is for GEN 1 ONLY.



SINGLE STAGE STD REBUILD KIT

625-4180

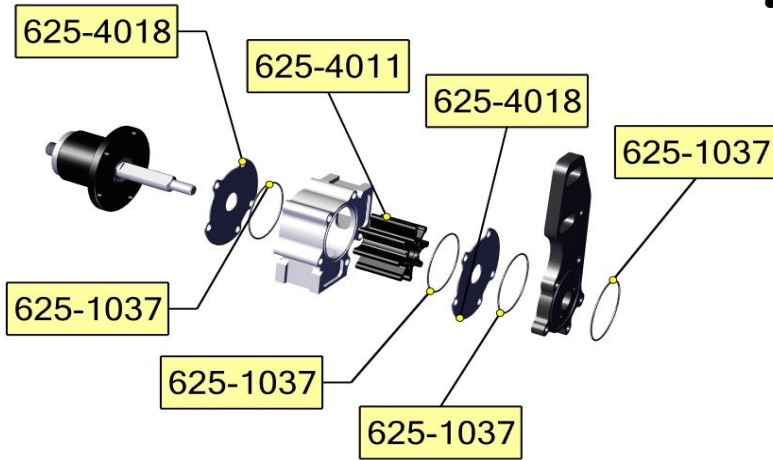

- **Step 8 Gen 2:**

- 1) Slide the components onto the shaft as shown,
- 2) Gen 2 uses only 625-4018 wear plates without holes.

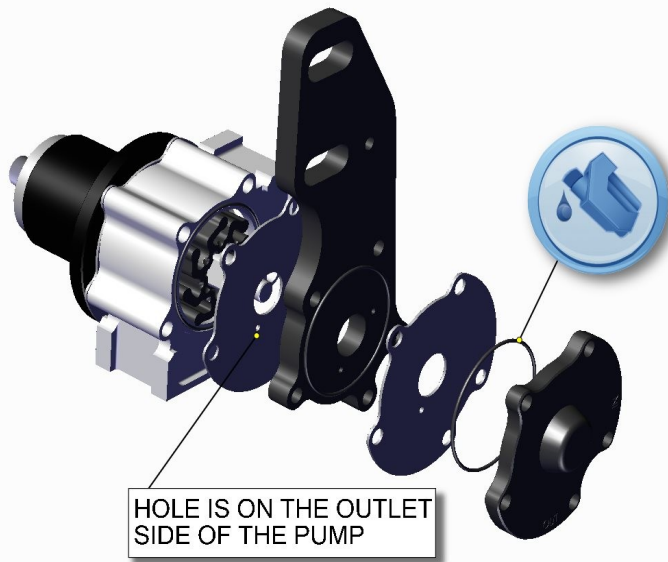

- **Step 9 Gen 1:**

- 1) Apply petroleum jelly to the 625-1037 and install into the groove in the rear cover.
- 2) Apply petroleum jelly to the end of the shaft.
- 3) Install 625-4019 wear plate, notice the hole in the plate position. Install rear cover.

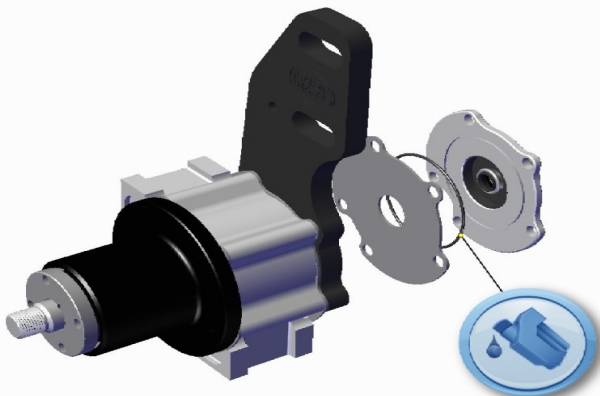

- **Step 9 Gen 2:**

- 1) Apply petroleum jelly to the 625-1037 and install into the groove in the rear cover.
- 2) Apply lubricate to the end of the shaft.
- 3) Install 625-4018 wear plate then tap on the rear cover.



SINGLE STAGE STD REBUILD KIT

625-4180



- **Step 10:**
 - 1) Install anti-sieze to the bolts.
 - 2) Install bolts with washers in from the back side.
 - 3) Slide 625-4022 over the bolts.
 - 4) Install washers and nuts. Using 1/2 socket torque to 25 ft. lbs..

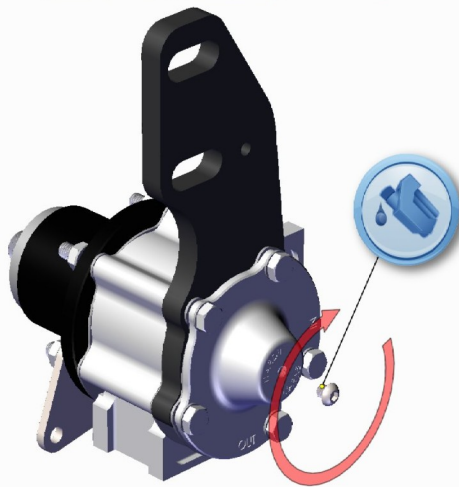

- **Step 11 Gen 2:**
 - 1) For gen 2 only.
 - 2) Apply anti-sieze to the bolt. Using 5/32 allen key install into the rear cover. Torque to 80 in. lbs..

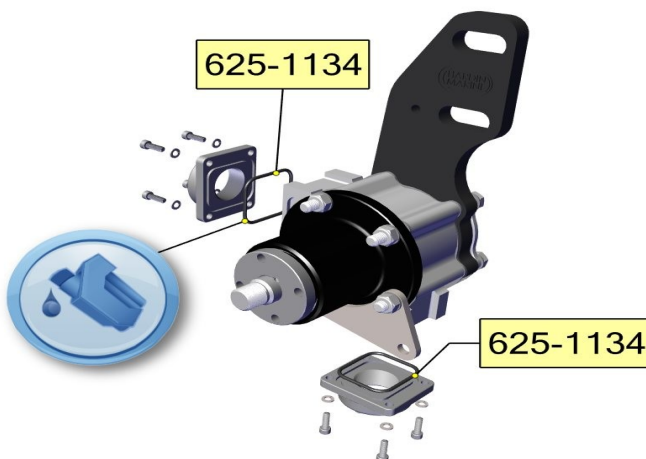

- **Step 12:**
 - 1) Using the supplied 625-1134 o-rings install.
 - 2) For Stainless bodies, apply anti-sieze to the bolts.
 - 3) For Aluminum bodies, apply loctite to the bolts.
 - 4) Using 5/32 hex socket, torque to 60 in. lbs..



SINGLE STAGE STD REBUILD KIT

625-4180

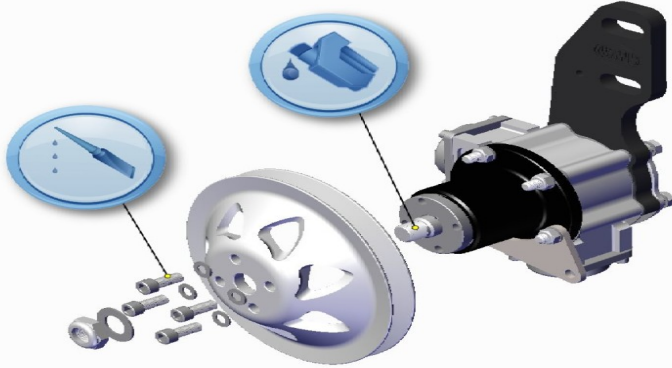

- **Step 13:**
 - 1) Apply anti-sieze to the shaft threads. Install pulley.
 - 2) Apply loctite to the 5/16 bolts. Using 1/4 socket torque to 25 ft. lbs..
 - 3) Install 5/8 nut and washer. Using 15/16 socket torque to 50 ft. lbs..