

HARDIN
MARINE

11 Industry Dr. Palm Coast, FL 32137
386-445-2500 / FAX 386-445-1122

PART NO.

137-8684

TITLE:

HARDIN/MERCURY TRIM TAB WIRING

www.hardin-marine.com

DASH PANEL TO HARDIN TRIM TAB WIRE COLOR CODE:

- 1) BLACK - GROUND
- 2) RED - 12V/ 5AMP FUSED KEYED POWER
- 3) YELLOW - DASH LIGHTS
- 4) BLUE - PORT SENDER BLUE WIRE (GROUND)
- 5) WHITE - PORT SENDER WHITE WIRE (SEND)
- 6) GREY - PORT SENDER RED WIRE (POWER)
- 7) BLUE - STBD SENDER BLUE WIRE (GROUND)
- 8) WHITE - STBD SENDER WHITE WIRE (SEND)
- 9) GREY - STBD SENDER RED WIRE (POWER)

DASH PANEL TO MERCURY TRIM TAB WIRE COLOR CODE:

- 1) BLACK - GROUND
- 2) RED - 12V/ 5AMP FUSED KEYED POWER
- 3) YELLOW - DASH LIGHTS
- 4) BLUE - PORT SENDER BLACK WIRE
- 5) WHITE - PORT SENDER GREEN WIRE
- 6) GREY - PORT SENDER PURPLE WIRE
- 7) BLUE - STBD SENDER BLACK WIRE
- 8) WHITE - STBD SENDER GREEN WIRE
- 9) GREY - STBD SENDER PURPLE WIRE

ADJUSTING THE LED LIGHT RANGE:

- 1) TRIM TABS COME FROM FACTORY ADJUSTED SO THE BOTTOM OF THE SENDER SHOULD BE ON.
- 2) BOTH SENDERS MUST BE WIRED AND THE BOTTOM LIGHT ON BOTH SIDES MUST BE LIT.
- 3) MOVE THE DRIVE/TAB ALL THE WAY UP.
- 4) USING 1/16 ALLEN KEY, REMOVE THE BACK COVER ON THE DASH PANEL.
- 5) USING A SMALL FLAT BLADE SCREWDRIVER, **CAREFULLY** TURN THE ADJUSTMENT ON THE BACK OF THE LED PANEL ALL THE WAY COUNTERCLOCKWISE. SOME OF THE TOP LED'S SHOULD TURN OFF.
- 6) SLOWLY TURN THE ADJUSTING SCREW CLOCKWISE UNTIL THE THE TOP LED LIGHT BEGINS TO ILLUMINATE. PANEL IS ADJUSTED FOR FULL RANGE. NOW ADJUST THE OTHER SIDE. CYCLE UP AND DOWN A FEW TIMES TO MAKE SURE LIGHTS ARE ADJUSTED PROPERLY.
- 7) REINSTALL REAR COVER.
- 9) 2 SLOT SHOWN. SAME INSTRUCTIONS FOR 4 AND 6 SLOT PANELS.

THIS DRAWING IS CONFIDENTIAL AND IS SUPPLIED ON EXPRESS CONDITION THAT IT SHALL NOT BE LENT, COPIED OR DISCLOSED TO ANY OTHER PERSON OR USED FOR ANY OTHER PURPOSE WITHOUT WRITTEN CONSENT OF HARDIN MARINE INC.. BREACH OF THIS CONTRACT WILL HOLD AND IT'S PRINCIPALS LIABLE FOR LOSS AND DAMAGES.

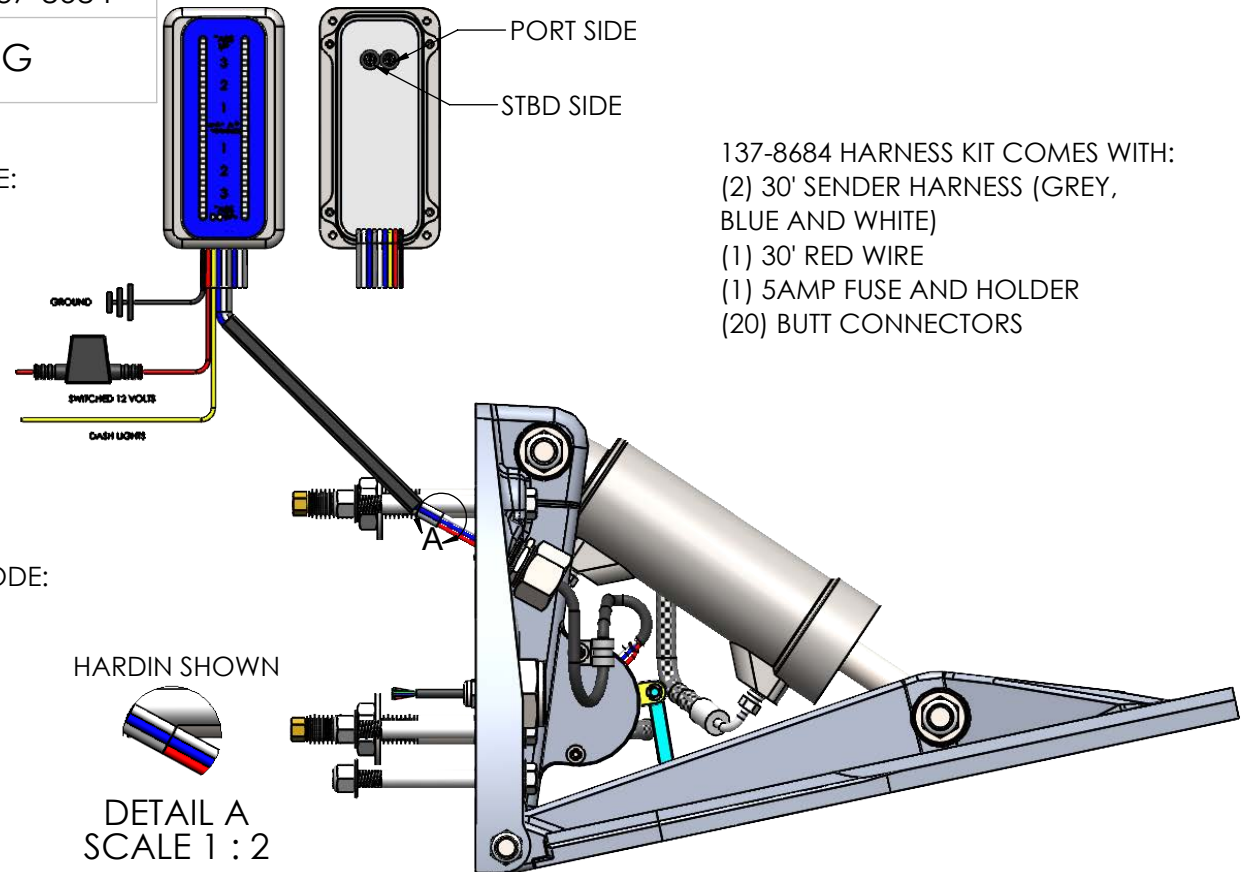

WARNING:
ATTACHING POWER TO ANY OTHER WIRE THAN THE RED, PURPLE OR GREY WIRE WILL PERMENANTLY DAMAGE THE SENDER AND DASH PANEL.

HARDIN
MARINE

11 Industry Dr. Palm Coast, FL 32137
386-445-2500 / FAX 386-445-1122

PART NO.

137-8684

TITLE:

3 WIRE SENDER WIRING

www.hardin-marine.com

DASH PANEL TO 3 WIRE SENDER WIRE COLOR
CODE:

- 1) BLACK - GROUND
- 2) RED - 12V/ 5AMP FUSED KEYED POWER
- 3) YELLOW - DASH LIGHTS
- 4) BLUE - PORT SENDER BLUE WIRE
- 5) WHITE - PORT SENDER WHITE WIRE
- 6) GREY - PORT SENDER RED WIRE
- 7) BLUE - STBD SENDER BLUE WIRE
- 8) WHITE - STBD SENDER WHITE WIRE
- 9) GREY - STBD SENDER RED WIRE

WARNING:
ATTACHING POWER TO ANY OTHER WIRE THAN
THE RED OR GREY WIRE WILL PERMENANTLY
DAMAGE THE SENDER AND DASH PANEL.

USED IN 137-8144, 137-8687, 137-8689, 137-8690 & 137-8729 ACTUATOR KITS

ADJUSTING THE LED LIGHT RANGE FOR MERCURY SMARTCRAFT/3 WIRE SENDER:

- 1) MOVE THE DRIVE/TAB ALL THE WAY DOWN.
- 2) BOTH SENDERS MUST BE WIRED AND THE BOTTOM LIGHT ON BOTH SIDES MUST BE LIT. IF ONLY ONE SENDER IS BEING USED, WIRE BOTH SIDES OF THE DASH PANEL TO THE SINGLE SENDER.
- 3) ADJUST THE MERCURY SENDER SO THE BOTTOM LIGHT IS ON. WHEN TIGHTENING THE BOLTS, THE LIGHT MIGHT TURN OFF OR SHOW TWO LIGHTS. IF SO, LOOSEN BOLTS, ADJUST SENDER AND TIGHTEN BOLTS AGAIN. SENDER IS VERY SENSITIVE TO MOVEMENT.
- 4) MOVE THE DRIVE/TAB ALL THE WAY UP.
- 5) USING 1/16 ALLEN KEY, REMOVE THE BACK COVER.
- 6) USING A SMALL FLAT SCREWDRIVER, **CAREFULLY** TURN THE ADJUSTMENT SCREW ON THE BACK OFF THE LED PANEL ALL THE WAY COUNTERCLOCKWISE. SOME OF THE TOP LED'S SHOULD TURN OFF.
- 7) SLOWLY TURN THE ADJUSTING SCREW CLOCKWISE UNTIL THE THE TOP LED LIGHT BEGINS TO ILLUMINATE. PANEL IS NOW ADJUSTED FOR FULL RANGE. NOW ADJUST THE OTHER SIDE. CYCLE UP AND DOWN A FEW TIMES TO MAKE SURE LIGHTS ARE ADJUSTED PROPERLY.
- 8) REINSTALL REAR COVER.
- 9) 2 SLOT SHOWN. SAME INSTRUCTIONS FOR 4 AND 6 SLOT PANELS.

137-8684 HARNESS KIT COMES WITH:
(2) 30' SENDER HARNESS (GREY, BLUE
AND WHITE)
(1) 30' RED WIRE
(1) 5AMP FUSE AND HOLDER
(20) BUTT CONNECTORS

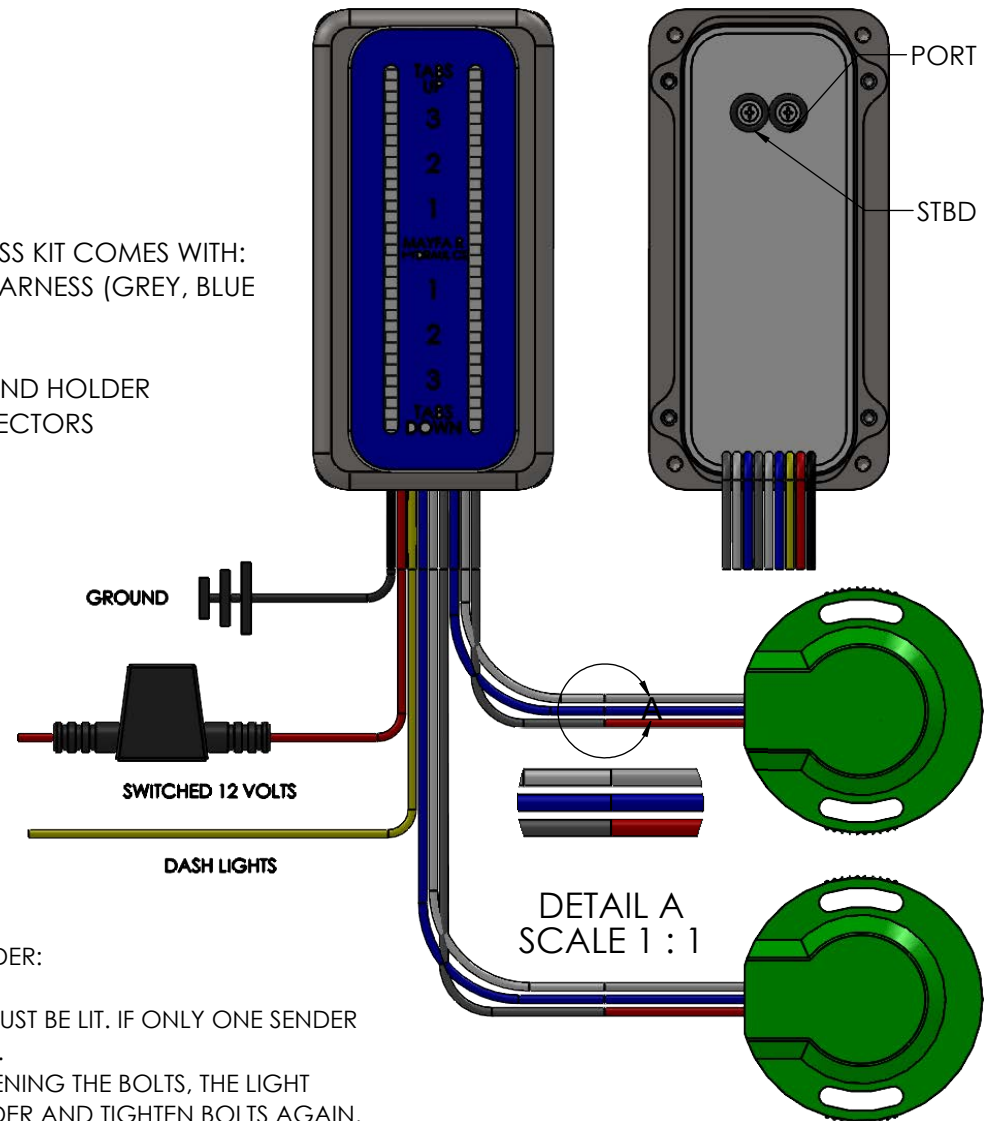

HARDIN
MARINE

11 Industry Dr. Palm Coast, FL 32137
386-445-2500 / FAX 386-445-1122

PART NO.

137-8406

TITLE:

2 LED TRIM/DRIVE PANEL

www.hardin-marine.com

ADJUSTING THE LED LIGHT RANGE FOR MERCURY SMARTCRAFT/3 WIRE SENDER:

- 1) USING 1/16 ALLEN KEY, REMOVE THE BACK COVER.
- 2) MOVE TO DRIVE/TAB ALL THE WAY DOWN.
- 3) ADJUST THE MERCURY SENDER SO THE BOTTOM LIGHT IS ON.
- 4) MOVE TO DRIVE/TAB ALL THE WAY UP.
- 5) USING A SMALL SCREWDRIVE, **CAREFULLY** TURN THE ADJUSTMENT ON THE BACK OFF THE LED PANEL ALL THE WAY COUNTERCLOCKWISE. SOME OF THE TOP LED'S SHOULD TURN OFF.
- 6) SLOWLY TURN THE ADJUSTING SCREW CLOCKWISE UNTIL THE THE TOP LED LIGHT BEGINS TO ILLUMINATE. PANEL IS ADJUSTED FOR FULL RANGE. NOW ADJUST THE OTHER SIDE.
- 7) REINSTALL REAR COVER.
- 8) SAME FOR 2, 4 AND 6 SLOT INSTALLATIONS.

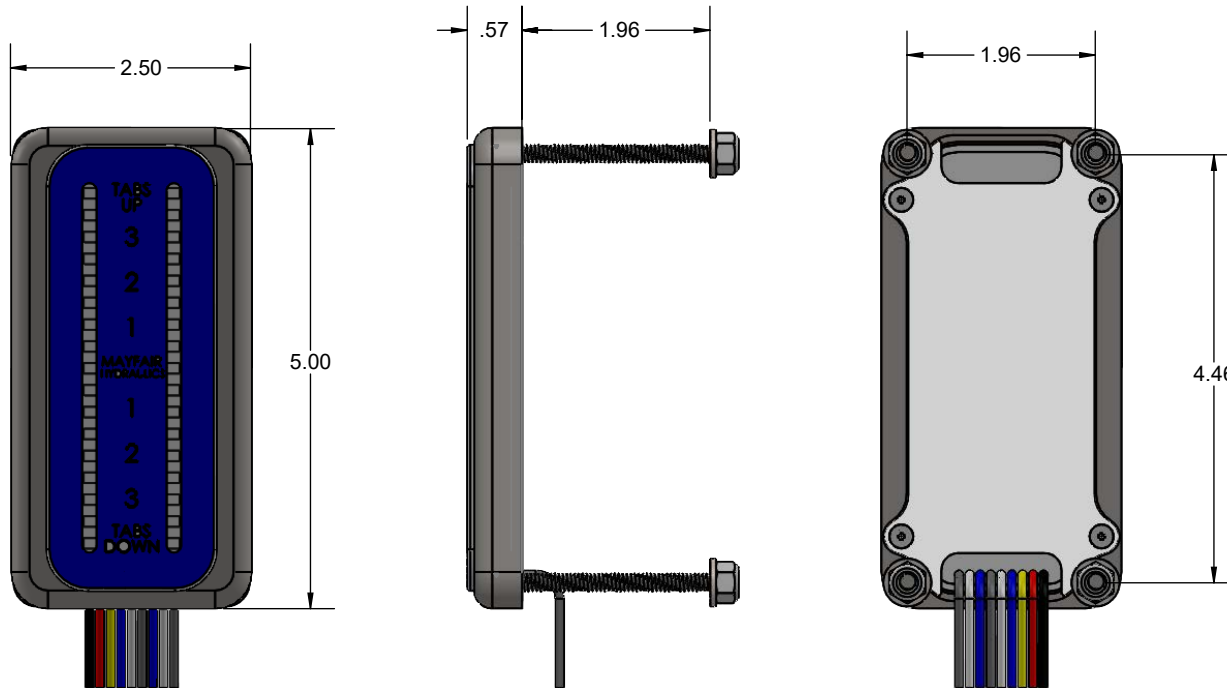
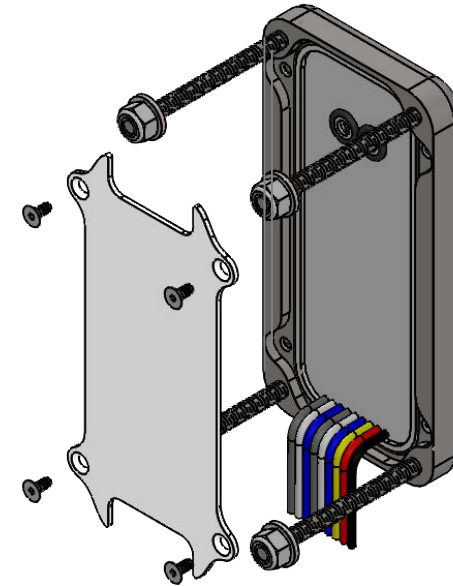

WIRE COLOR CODE:

- 1) BLACK - GROUND
- 2) RED - 12V/ 5AMP FUSED KEYED POWER
- 3) YELLOW - DASH LIGHTS
- 4) BLUE - PORT SENDER GROUND
- 5) WHITE - PORT SENDER SIGNAL
- 6) GREY - PORT SENDER 5V POWER
- 7) BLUE - STBD SENDER GROUND
- 8) WHITE - STBD SENDER SIGNAL
- 9) GREY - STBD SENDER 5V POWER

THIS DRAWING IS CONFIDENTIAL AND IS SUPPLIED ON EXPRESS CONDITION THAT IT SHALL NOT BE LENT, COPIED OR DISCLOSED TO ANY OTHER PERSON OR USED FOR ANY OTHER PURPOSE WITHOUT WRITTEN CONSENT OF HARDIN MARINE INC.. BREACH OF THIS CONTRACT WILL HOLD AND IT'S PRINCIPALS LIABLE FOR LOSS AND DAMAGES.

MAYFAIR PERFORMANCE

PART NO.

TITLE: 2 SLOT DASH PANEL CUTOUT

www.hardin-marine.com

USE 1/4 DRILL BIT FOR MOUNTING HOLES

DASH PANEL OUTSIDE PROFILE

USE 1/2 DRILL BIT FOR WIRE SLOTS. USE JIGSAW TO CUTOUT BETWEEN THE 2 HOLES.

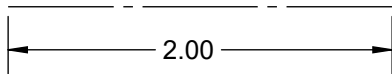

MAKE SURE PRINTER IS SET TO 1:1 SCALE WHEN PRINTING. MEASURE THIS LINE TO INSURE CORRECT SCALE.

