

91-805747A2

TIMING TOOL FOR MERCUISER EFI ENGINES

IMPORTANT: The engine must be completely warmed-up to normal operating temperature before checking or adjusting timing. Also, throttle must be advanced before connecting timing tool, to avoid engine stalling [The idle air control (IAC) valve closes air passage when engine is placed in the "Service Mode" - when timing tool is installed].

1. Connect timing light to #1 ignition wire.
2. Adjust engine throttle to 1800 RPM \pm 200.
3. Connect timing tool to the Data Link Connector (DLC) which is located in the engine electrical box.
4. Check and adjust timing in the normal manner. Remove timing tool when finished timing engine.

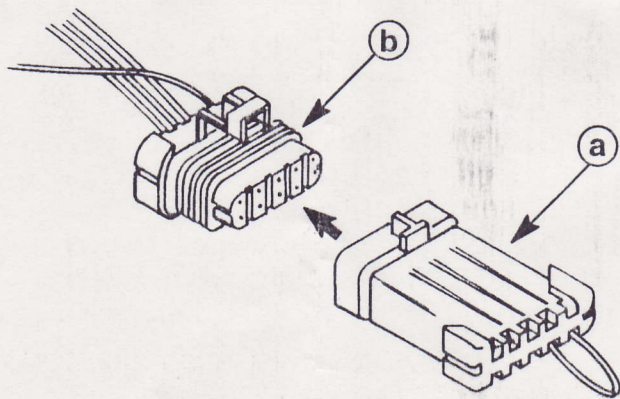

71839

- a** - Timing Tool
b - DLC Connector

Products of Mercury Marine
W6250 Pioneer Road
Fond du Lac, WI 54936-1939

The following are registered trademarks of Brunswick Corporation: Autoblend, Force, Jet-Prop, Mariner, Merc, MerCathode, MerCruiser, Mercury, Mercury Marine, Quicksilver, Ride-Guide, and Thruster.